

## Sentry Water Softener



Alamo Water Softeners  
(210) 274-6122  
3823 Thousand Oaks Dr  
San Antonio, TX 78217

# TABLE OF CONTENTS

<p>Introduction . . . . .1</p> <p style="padding-left: 20px;">General Warnings . . . . .1</p> <p style="padding-left: 20px;">Principles Of Softening-Ion Exchange . . . . .2</p> <p style="padding-left: 20px;">Specifications . . . . .5</p> <p style="padding-left: 20px;">Quick Reference Specifications . . . . .5</p> <p>Control Valve Function and Cycles of Operation . . . . .6</p> <p style="padding-left: 20px;">Regeneration Steps And Purpose . . . . .6</p> <p style="padding-left: 20px;">Exchange Capacity Data . . . . .7</p> <p>Installation . . . . .7-10</p> <p>Control Valve Setup . . . . .10-12</p> <p>Sanitizing Water Softener . . . . .12</p> <p>Components . . . . .12</p> <p style="padding-left: 20px;">Drive Assembly . . . . .14</p> <p style="padding-left: 20px;">Drive Cap Assembly, Main piston And Regenerant Piston . . . . .14</p> <p style="padding-left: 20px;">Spacer Stacker Assembly . . . . .14</p> <p style="padding-left: 20px;">Injector Cap, Screen, Injector Plug And Injector . .15</p> <p style="padding-left: 20px;">Injector Order Information . . . . .15</p> <p style="padding-left: 20px;">Refill Flow Control Assembly or Refill Port Plug . .15</p> <p style="padding-left: 20px;">Drain Line Flow Control and Fitting Assembly . . .16</p> <p style="padding-left: 20px;">Drain Line Flow Control and Fitting Order Information . . . . .16</p> <p style="padding-left: 20px;">Water Meter or Meter Plug . . . . .16</p> <p style="padding-left: 20px;">Installation Fitting, Assemblies . . . . .17</p> <p style="padding-left: 20px;">Bypass Valve . . . . .17-18</p>	<p>Service Instructions . . . . .19</p> <p style="padding-left: 20px;">Drive Assembly . . . . .19</p> <p style="padding-left: 20px;">Drive Cap Assembly, Main Piston and Regenerate Piston . . . . .20</p> <p style="padding-left: 20px;">Spacer Stack Assembly . . . . .21</p> <p style="padding-left: 20px;">Injector Cap, Screen, Injector Plug and Injector . .21</p> <p style="padding-left: 20px;">Refill Flow Control Assembly or Refill Port Plug . .22</p> <p style="padding-left: 20px;">Water Meter or Meter Plug . . . . .22</p> <p style="padding-left: 20px;">Bypass Valve . . . . .23</p> <p>Drawings and Part Numbers . . . . .24</p> <p style="padding-left: 20px;">Front Cover and Drive Assembly . . . . .25</p> <p style="padding-left: 20px;">Drive Cap Assembly, Downflow Piston, Upflow Piston, Regenerant Piston and Spacer Stack Assembly . . . . .26</p> <p style="padding-left: 20px;">Injector Cap, Injector Screen, Injector, Plug, and O-ring . . . . .27</p> <p style="padding-left: 20px;">Refill and Refill Port Plug . . . . .28</p> <p style="padding-left: 20px;">Drain Line – 3/4” . . . . .29</p> <p style="padding-left: 20px;">Water Meter and Meter Plug . . . . .30</p> <p style="padding-left: 20px;">Installation Fitting, Assemblies . . . . .31</p> <p style="padding-left: 20px;">Bypass Valve . . . . .32</p> <p style="padding-left: 20px;">Flow Diagrams - Service and Backwash . . . . .33</p> <p style="padding-left: 20px;">Flow Diagrams - Downflow and Upflow . . . . .34</p> <p style="padding-left: 20px;">Flow Diagrams - Rinse and Fill . . . . .35</p> <p style="padding-left: 20px;">WS1 Wrench . . . . .36</p> <p style="padding-left: 20px;">System Troubleshooting, . . . . .37-38</p> <p style="padding-left: 20px;">Valve Troubleshooting . . . . .39-40</p> <p>Limited Warranty . . . . .41</p>
---	--

## RESIDENTIAL WATER CONDITIONING LIMITED WARRANTY

This Water Conditioner is guaranteed to be free of material or manufacturing defects at the time of installation, where originally installed. The warranty period begins on the installation date, but shall not begin later than six (6) months from the date of manufacture.

There is a five (5) year warranty on Fiberglass resin tanks; 5 year warranty on salt tank and control valve; 1 year warranty on component materials and workmanship. Water softener resins subjected to iron, manganese, and chlorine levels greater than 1 ppm are expressly not covered by the 5 year warranty.

Labor is not included. Warranty is limited to repair or replacement of defective part (manufacturer's choice). Freight and shipping are not covered by this warranty, and are for the customer's account. **Return Goods Authorization (RGA) required on returns. Collect freight returns will not be accepted.**

This limited warranty does not cover failure in service due to fire, freezing, abuse, shipping damages, misapplication, sunlight damage, high temperature failure (i.e. hot water back up), improper electrical connection or hi/low voltage, nor does it extend to consequential damages such as water damage, or salt damage.

**Distributed by:** \_\_\_\_\_ **Date:** \_\_\_\_\_ **Model #:** \_\_\_\_\_ **Serial #:** \_\_\_\_\_

---

## INTRODUCTION

---

### General Warnings

The control valve, fittings and, or bypass are designed to accommodate minor plumbing misalignments but are not designed to support the weight of a system or the plumbing.

Do not use Vaseline, oils, other hydrocarbon lubricants or spray silicone anywhere. A silicon lubricant may be used on black o-rings but is not necessary. **Avoid any type of lubricants, including silicone, on red or clear lip seals.**

The nuts and caps are designed to be unscrewed or tightened by hand or with the special plastic wrench. If necessary a pliers can be used to unscrew the nut or cap. Do not use a pipe wrench to tighten or loosen nuts or caps. Do not place screwdriver in slots on caps and/or tap with a hammer.

Do not use pipe dope or other sealants on threads, Teflon tape must be used on the threads of the 1" NPT elbow or the 1/4" NPT connection and on the threads for the drain line connection. Teflon tape is not necessary on the nut connection or caps because of o-ring seals.

After completing any valve maintenance involving the drive assembly or the drive cap assembly and pistons, press the NEXT and REGEN buttons for 3 seconds or unplug power source jack from the printed circuit board (black wire) and plug back in. This resets the electronics

and establishes the service piston positions. The display should flash all wording, then flash the software version (e.g. 154) and then reset the valve to the service position. All plumbing should be done in accordance with local plumbing codes. The pipe size for the drain line should be a minimum of 1/2". Backwash flow rates in excess of 7 gpm or length in excess of 20' require 3/4" drain line.

Solder joints near the drain must be done prior to connecting the drain line flow control fitting. Leave at least 6" between the drain line control fitting and solder joints when soldering pipes that are connected on the drain line control fitting. Failure to do this could cause interior damage to the drain line flow control fitting.

When assembling the installation fittings package (inlet and outlet), connect the fitting, to the plumbing system first and then attach the nut, split ring and o-ring. Heat from soldering or solvent cements may damage the nut, split ring or o-ring. Solder joints should be cool and solvent cements should be set before installing the nut, split ring, and o-ring. Avoid getting primer and solvent cement on any part of the o-rings, split rings, bypass valve or control valve.

Plug into an electrical outlet. Note: All electrical connections must be connected according to local codes. (Be certain the outlet is uninterrupted.)

Install grounding strap on metal pipes.

### Principles of Softening and Ion-Exchange

Softening of water by the exchange process involves the exchange or substitution of the hardness minerals, chiefly calcium and magnesium, for sodium minerals. The exchange is made possible because the minerals are ionic in nature (often called ionized impurities) which means they have an electrical charge. The ion exchange process is based on the fact that like charges repel one another, and unlike charges attract.

Calcium and magnesium ions in water are actually dissolved rock. They have been dissolved by water, the "universal solvent", as it trickles down through strata of rock and soil it dissolves calcium and magnesium deposits. This dissolved rock eventually finds its way into an underground aquifer and when water from the aquifer is pumped to the surface, it contains the dissolve hardness minerals of calcium and magnesium and is said to be hard water.

An ion exchange softener exchanges the hardness minerals, calcium, and magnesium, for sodium, from the softener resin. Sodium is less objectionable because it does not build up on surfaces as scale deposits.

All three minerals are positively charged ions called cations. The exchange takes place by passing water containing hardness minerals over a man-made ion exchange resin contained in a suitable tank. The resin, polystyrene divinyl benzene in most-modern softeners, consist of millions of tiny plastic beads, all of which contain many negatively charged exchange sites to attract the positive cations. When the resin is in the regenerated state these negatively charged exchange sites hold positively charged sodium cations.

As the calcium and magnesium contact the resin beads in their travel through the resin tank, they displace the sodium ions from the exchange sites. During the ion exchange process, relatively small amounts of other strongly charged cations such as iron and manganese are also removed along with the calcium and magnesium.

Ion exchange is possible for two reasons: (1) All cations do not have the same strength of positive charge and (2) the resin prefers the stronger charged cations calcium and magnesium than it does the weaker sodium cations.

The exchanged sodium cations pass downward through the resin "bed" and out the softener outlet, thus, the softener delivers "soft" water.

Eventually, all of the resin exchange sites are occupied by calcium and magnesium and no further exchange can take place. The resin is said to be exhausted and must be regenerated.

The softener resin is regenerated with a dilute brine solution of sodium chloride (common salt) and water. During regeneration the flow of service water from the softener is first stopped. Brine is drawn from the brine tank mixing with a separate stream of water. The brine solution flows through the resin, contacting the resin beads loaded with calcium and magnesium ions. Even though the calcium and magnesium are more strongly charged than the sodium, the concentrated brine solution contains literally billions of weaker charged sodium ions which have the power to displace the smaller number of calcium and magnesium ions. When the calcium and magnesium ions are displaced, the positive sodium ions are attracted to the negative exchange sites is said to be regenerated and ready for the next softening cycle.

# INTRODUCTION

## Specifications TABLE I

Minimum/Maximum Operating Pressures	20 psi (138 kPa) -125 psi (862 kPa)
Minimum/Maximum Operating Temperatures	40°F (4°C) -110°F (38°C)
Current Draw & Voltage	0.5 Amperes 110 Volts Other options available

Table 2 contains a summary of specifications for the control valve and bypass valve.

## Quick Reference Specifications TABLE 2

Service flowrate (includes bypass)	27 gpm (102.2 lpm) @ 15 psig (103 kPa) drop
Backwash flowrate (includes bypass)	27 gpm (102.2 lpm) @ 25 psig (172 kPa) drop
Minimum/Maximum Operating Pressures	20 psi (138 kPa) -125 psi (862 kPa)
Minimum/Maximum Operating Temperatures	40°F (4°C) - 100°F (38°C)
Current Draw & Voltage	0.5 Amperes 110 Volts Other options available
Regenerant Refill Rate	0.5 gpm (1.9 lpm)
Injectors	See Injector Graphs
Drain Line Flow Controls	See Table 11
Inlet/Outlet Fitting Options	(a) 1" NPT elbow which has a unique drill out feature to allow a 1/4" NPT connection to the inlet and/or outlet (b) 3/4" & 1" PVC solvent weld fitting (c) 1" straight brass sweat fitting (d) 3/4" straight brass sweat fitting
Distributor Tube Opening	1.05" Diameter (3/4" U.S. PVC Pipe Size)
Tank Thread	2-1/2" - 8 NPSM
Control Valve Weight	4.5 lbs 2.0 kg
PC Board Memory	Nonvolatile EEPROM (Electrically erasable programmable read only memory)
Compatible with regenerants/chemicals	Sodium chloride, potassium chloride, potassium permanganate, sodium bisulfite, sodium hydroxide, hydrochloric acid, chlorine and chloramines

MODEL	PIPE SIZE	MINERAL TANK		BRINE TANK		SOFTENING CAPACITY		LBS. SALT PER REGEN		FLOW RATE & PRESSURE		BKW GPM
		TANK SIZE	RESIN CU. FT.	SIZE	SALT FILL	MAX	MIN	MAX	MIN	SERV GPM	DROP PSI	
M3011-W100SM	1"	9 X 48	1	18 X 36	300	30K	20K	15	6	15	15	2.0
M3013-W100SM	1"	10 X 54	1.5	18 X 36	300	45K	30K	22	9	16	15	2.7
M3015-W100SM	1"	12 X 52	2	18 X 36	300	60K	40K	30	12	20	15	3.2
M3017-W100SM	1.25/1.5	13 X 65	3	18 X 36	300	90K	60K	45	18	21	15	5.3
M3019-W100SM	1.25/1.5	16 X 65	4	18 X 36	300	120K	80K	60	24	22	15	7.5
M3021-W100SM	1.25/1.5	21 X 62	7	24 X 41	600	210K	140K	105	42	24	15	11.0

---

## CONTROL VALVE FUNCTIONS

---

### Control Valve Function and Cycles of Operation

This glass filled Noryl fully automatic control valve is designed as the primary control center to direct and regulate all cycles of a water softener. The control valve can be set to regenerate on demand (consumption of a predetermined amount of water) and/or as a time clock (passage of a particular number of days).

The control valve is compatible with a variety of regenerants and resin cleaners. The control valve is capable of routing the flow of water in the necessary paths to regenerate or backwash water treatment systems. The injector regulates the flow of brine or other regenerants. The control valve regulates the flow rates for backwashing rinsing and the replenishing of treated water into a regenerant tank.

The control valve is designed to deliver high service (27 gpm @ 15 psig) and backwash (27 gpm @ 25 psig) flow rates when the bypass has straight fittings. The control valve uses no traditional fasteners (e.g. screws), instead clips, threaded caps and nuts and snap type latches are used. Caps and nuts only need to be firmly hand tightened because radial seals are used. Tools required to service the valve include one small blade screwdriver, one large blade screwdriver, pliers and a pair of hands. A plastic wrench is available which eliminates the need for screwdrivers and pliers. Disassembly for servicing takes much less time than comparable products currently on the market.

The transformer power pack comes with a 15-foot power cord and is designed for use with the control valve. The transformer power pack is for dry location use only. The control valve remembers all settings for two hours if the power goes out. After two hours the only item that needs to be reset is the time of day, all other values are permanently stored in the nonvolatile memory. The control valve does not need batteries.

When the control valve is used as a down flow softener, two backwashes always occur. The softener will start regenerant prefill before regeneration, the prefill starts two hours before the regeneration time set. During the 2-hour period in which the brine is being made, treated (softened) water is still available. For example: regeneration time = 2:00 am, prefill option selected, downflow softener. Fill occurs at 12:00 a.m., start of backwash cycle occurs at 2:00 a.m.

The softener will adjust the backwash and rinse cycles automatically when the salt dosage is changed. Backwashes can be set to be NORMAL or LONGER. The option selected will apply to all backwashes. Tables 4 and 5 show the length of the cycles when the valve is set up as a softener.

---

#### REGENERATION STEPS AND PURPOSE:

**Brine fill** – Brine tank is filled to dissolve salt for next regeneration.

**Backwash** – Flow through the resin bed is reversed. Water flows upward expanding and agitating the resin bed.

**Brine in** – Brine is educted from the brine tank and passes through the resin bed in a downward flow, thus removing calcium and magnesium that has accumulated on the resin beads and is flush to drain.

**Backwash** – A second backwash is performed

**Rinse** – The resin is now flushed downward at a set flow rate. This resettles the bed and rinses out any remaining brine left in the resin bed.

**Service** – Softener goes back into service and ready to soften water.

#### EXCHANGE CAPACITY DATA

20,000 grain approx. per cu. Ft.  
6 lbs. salt-sodium chloride

25,000 grain approx. per cu. Ft.  
8 lbs. salt-sodium chloride

30,000 grain approx. per cu. Ft.  
15 lbs. salt-sodium chloride

**Note:** To convert parts per million (PPM) or milligrams per liter (mpl) to grains divide by 17.1

**Example:** Water hardness of 250 PPM  
(250 PPM divided by 17.1 PPM/gr.) equals 14.6 gr.

It is recommended that a good grade of solar or pellet salt be used.

One-gallon water will dissolve approximately 3.0 lbs. of salt

One gallon of saturated brine weighs 10.74 lbs.

# CONTROL PROGRAMMING

DIR	TIME CLOCK	RESERVE CAPACITY	SOFTENER	FILTER		SETTINGS*	
				REGENERANT	BACKWASH ONLY	DAY OVERRIDE	GALLON CAPACITY
Yes		Automatically Calculated Yes Off Auto	Yes			Off	Auto
Yes		If desired enter a value less than estimated capacity	Yes	Yes	Yes	Off	Any Number
Yes	Yes	Automatically calculated	Yes			Any Number	Auto
Yes	Yes	If desired enter a value less than estimated capacity	Yes	Yes	Yes	Any Number	Any Number
	Yes	None	Yes	Yes	Yes	Any Number	Off

\* Day override AND Gallon Capacity cannot be set to "off" at the same time

## DIR/TIME CLOCK OPTIONS

For DIR Softeners, there are two options for setting the Gallons Capacity. The Gallons Capacity is automatically calculated if set to AUTO. Reserve Capacity, is automatically estimated based on water usage if AUTO is used. The other option is to set the Gallons Capacity to a specific number. If a specific number is set, reserve capacity is zero, unless the value is manually set (i.e. the manufacturer intentionally sets the gallon capacity number below the calculated capacity of the system).

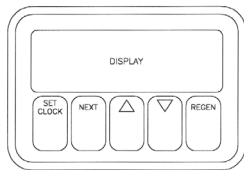

Figure 15: Key Pad

This control valve is set up in the AUTO mode; it can also be set to regenerate immediately or at the next regeneration time by changing the Regeneration Time Option. There are three choices for settings:

1. "NORMAL" means regeneration will occur at the pre set regeneration time.
2. "On 0" means regeneration will occur when the gallons capacity reaches zero.
3. "NORMAL" and "on 0" means the regeneration will occur at the preset regeneration time unless the gallons capacity reaches zero. If the gallon capacity reaches zero, the regeneration will begin 10 minutes after no water usage.

The user can initiate manual regeneration. The user has the option to request the manual regeneration at the delayed regeneration time or to have the regeneration occur immediately:

1. Pressing and releasing the REGEN button. "Regen today" will flash on the display and the regeneration will occur at the delayed regeneration time. The user can cancel the request by pressing and releasing the REGEN button. This method of manually initiating regeneration is not allowed when the system is set to immediately regenerate when the capacity reaches zero.
2. Pressing and holding the REGEN button for approximately 3 seconds will immediately start the regeneration. The user cannot cancel this request, except by resetting the control by pressing NEXT and REGEN buttons simultaneously for 3 seconds.

## FACTORY DEFAULT PROGRAMMING

**To change press and hold NEXT & ▼**

1. Configuration .....Softener
2. Grain Capacity .....\*
3. Pounds of salt per regeneration .....\*
4. Backwash Duration .....Normal
5. Gallons Capacity .....Auto
6. Brine Refill .....Pre
7. Regenerant Flow .....dn
8. Regeneration Initiation .....Normal +0

**Installer Setup: Press NEXT & ▲**

1. Hardness ..... "grains"
2. Calendar Override .....
3. Time of Regeneratiuon (hour) ..... :2:00AM
4. Time of Regeneratiuon (minute) ..... :2:00AM

**Diagnostics: Press ▼ & ▲**

1. Number of days since last regeneration
2. Number of gallons since last regeneration
3. Reserve capacity gallons used in last 7 days
4. Daily gallon usage for last 64 days
5. Current flow rate
6. Maximum flow rate in the last seven days
7. Total gallons since the last reset
8. Number of days since last reset
9. Number of regenerations since the last reset

**Valve History: Press ▼ & ▲ then ▼ & ▲**

1. Software version
2. Maximum flow rate since start-up
3. Total number of gallons since start-up
4. Total number of days since start-up
5. Total Number of regenerations since start-up
6. Number of error occurrences since start-up

\* Refer to specification table 2 page 4.

# CONTROL PROGRAMMING

## INSTALLER (I) Displays/Settings

**STEP 1I** – Press NEXT and arrow up simultaneously for 3 seconds.

**STEP 2I** – Hardness: Set the amount of hardness in grains of hardness as calcium carbonate per gallon using, arrow down or arrow up buttons. The default is 20 with value ranges from 1 to 150 in 1 grain increments. Note the grains per gallon can be increased if soluble iron needs to be reduced. Press NEXT to go to step 3I. Press REGEN to exit Installer Displays/Settings.

**STEP 3I** – Day Override: When gallon capacity is set to off, sets the number of days between regeneration's. When gallon capacity is set to AUTO or to a number sets the maximum number of days between regenerations. If value set to "off" regeneration initiation is based solely on gallons used. If value is set as a number (allowable range from 1 to 28) a regeneration initiation will be called for on that day even if sufficient number of gallons were not used to call for a regeneration. Set Day Override using arrow buttons to days between regeneration (1 to 28); or OFF.

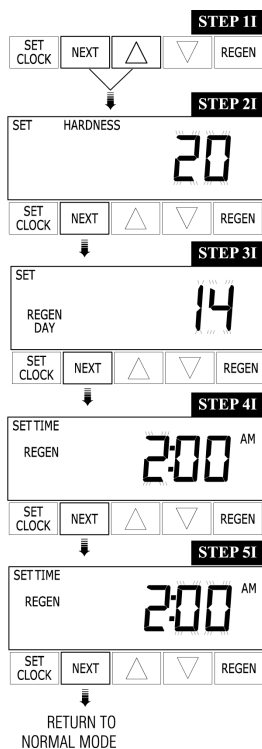

Press NEXT to go to step 4I. Press REGEN to return to previous step.

**STEP 4I** – Next Regeneration Time (hour): Set the hour of day for regeneration using down or up arrow buttons. AM/PM toggles after 12. The default time is 2:00 am. This display shows "REGEN on 0 GAL" if "on 0" is selected in Step 9S or Step 7F. Press NEXT to go to step 5I. Press REGEN to return to previous step.

**STEP 5I** – Next RegenerationTime (minutes): Set the minutes of day regeneration using the arrow buttons. This display will not be shown if "on 0" is selected in Step 9S or Step 7F. Press NEXT to exit Installer Displays/ Settings. Press REGEN to return to previous step.

To initiate a manual regeneration immediately, press and hold the "REGEN" button for three seconds. The system will beam to regenerate immediately. The control valve may be stepped through the various regeneration cycles by pressing the "REGEN" button.

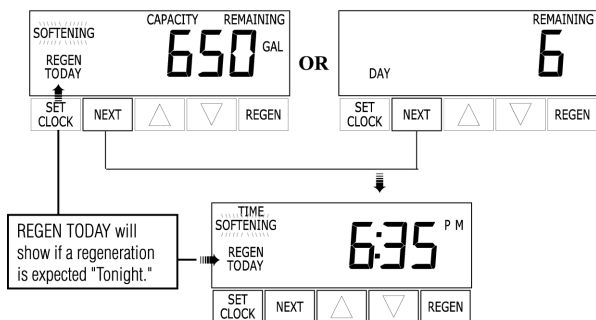

## General Operation

### User (U) Displays/Settings

When the system is operating one of two displays will be shown. Pressing NEXT will alternate between the displays. One of the displays is always the current time of day. The second display is one of the following: days remaining or gallons remaining. Days remaining are the number of days left before the system goes through a regeneration cycle. Capacity remaining is the number of gallons that will be treated before the system goes through a regeneration cycle. The user can scroll between the displays as desired.

If the system has called for a regeneration that will occur at the preset time of regeneration, the words REGEN TODAY will appear on the display.

When water is being treated (i.e. water is flowing through the system) the word "Softening" flashes on the display.

Note: If brine tank does not contain salt, fill with salt and wait at least two hours before regenerating.

## REGENERATION MODE

Typically a system is set to regenerate at a time of low water usage. An example of a time with low water usage is when a household is asleep. If there is a demand for water when the system is regenerating, untreated water will be used.



When the system begins to regenerate, the display will change to include information about the step of the regeneration process and the time remaining for that step to be completed. The system runs through the steps automatically and will reset itself to provide treated water when the regeneration has been completed.

## MANUAL

### REGENERATION

Sometimes there is a need to regenerate the system, sooner than when the system calls for it, usually referred to as manual regeneration. There may be a period of heavy water usage because of guests or a heavy laundry day.

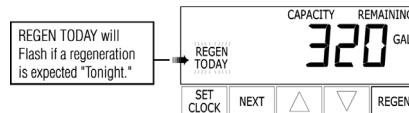

To initiate a manual regeneration at the preset delayed regeneration time, when the regeneration time option is set to "NORMAL" or "NORMAL + on 0", press and release "REGEN". The words "REGEN TODAY" will flash on the display to indicate that the system will regenerate at the preset delayed regeneration time. If you pressed the "REGEN" button in error, pressing the button again will cancel the request. Note: If the regeneration time option is set to "on 0" there is no set delayed regeneration time so "REGEN TODAY" will not activate if "REGEN" button is pressed.

To initiate a manual regeneration immediately, press and hold the "REGEN" button for three seconds. The system will begin to regenerate immediately. The request cannot be cancelled.

---

## PROGRAMMING (NOTE)

---

### SET TIME OF DAY

The user can also set the time of day. Time of day should only need to be set after extended power outages or when daylight savings time begins or ends. If an extended power outage occurs, the time of day will flash on and off which indicates the time of day should be reset.

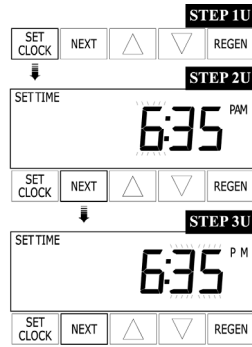

**STEP 1U** – Press SET CLOCK.

**STEP 2U** – Current Time (hour): Set the hour of the day using down or up arrow buttons. AM/PM toggles after 12. Press NEXT to go to step 3U.

**STEP 3U** – Current Time (minutes): Set the minutes of the day using down or up arrow buttons. Press NEXT to exit Set Clock. Press REGEN to return to previous step.

**POWER LOSS** If the power goes out for less than two hours, the system will automatically reset itself. If an extended power outage occurs, the time of day will flash on and off which indicates the time of day should be reset. The system will remember the rest.

**ERROR MESSAGE** If the word “ERROR” and a number are alternately flashing on the display contact the OEM for help. This indicates that the valve was not able to function properly.

---

## SANITIZING THE SYSTEM

---

1. At completion of softener installation you should sanitize the system.
2. Take the lid off of the salt tank and then take the cap off of the brine well. Pour about 3/4 to 1 1/2 ounce of 5.25% common household bleach into the brine well. Replace cap and lid. (This can be done with or without salt in tank.)
3. Press and hold regeneration button to start the regeneration process immediately.

Each water softener is handled in a manner to keep clean and sanitary. The materials used will not contaminate your water supply or cause bacteria to grow. However, during shipping, storage, installation, and operation, bacteria growth could develop. Some water supplies may require periodic disinfecting.

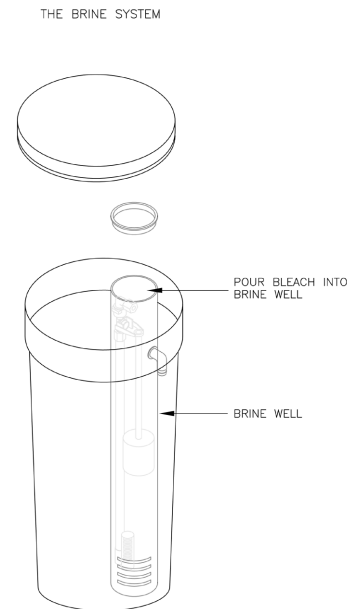

Figure 16:  
The Brine System

---

## SYSTEM COMPONENTS DESCRIBED

---

### Components:

The control valve consists of the following components

1. Drive Assembly
2. Drive Cap Assembly, Main Piston and Regenerant Piston
3. Spacer Stack Assembly
4. Injector Cap, Screen, Injector Plug and Injector
5. Refill Flow Control Assembly or Refill Port Plug
6. Drain Line Flow Control and Fitting Assembly
7. Water Meter or Meter Plug
8. Installation Fitting Assemblies
9. Bypass Valve (optional)

### DRIVE ASSEMBLY

The drive assembly consists of the following parts:

- Drive Bracket
- Printed Circuit (PC) Board
- Motor
- Drive Gears
- Drive Gear Cover

The drive bracket holds the PC board, the motor, the drive gears and the drive gear cover in place.

The PC board receives and retains information, displays the information, determines when to regenerate and initiates regeneration. The display shows different types of information in the initial system set up (for softeners or filters), installer displays/settings, diagnostics, and valve history or user displays/settings.

The PC board's two-prong jack connects wires to the direct current (DC) motor. The motor is held in place on the drive bracket by a spring-loaded clip and a small bulge in the plastic, which fits in one of the slots on the motor housing. The motor turns drive gears that drive the piston to cycle positions for backwashing, regeneration, rinsing, refill or service. The motor is fully reversible (turns both ways) and changes direction of rotation to change the direction of piston motion. The motor is easily replaced if necessary.

There are three drive gears held in place by the drive gear cover. All three drive gears are the same size. A reflective coating is applied to the gears. As the center drive gear turns a light shines on the coating and a light sensing diode determines if a light pulse was returned. The PC board counts the pulses and determines when to stop driving the motor.

# CONTENTS

## DRIVE CAP ASSEMBLY

### Main Piston and Regenerant Piston

The drive gears turn the main gear of the drive cap assembly, which moves the piston. The screw-driven, horizontally moving piston stops at specific positions to direct the flow of water to backwash, regenerate, rinse or refill. The PC board determines the position of the piston by counting pulses produced when the piston is moved. An optical sensor looking at one of the reduction drive gears generates these pulses. Each cycle position is defined by a number of pulses. The counter is zeroed each time the valve goes to the service position. The PC board finds the service position by noting the increase in current delivered to the motor when the mechanical stop at the service position is reached. This method of controlling piston position allows for greater flexibility and requires no switches or cams.

One of two main pistons is always used:

1. The down flow piston which is used when the control valve is used as a down flow softener, regenerating filter or nonregenerating filter: or
2. The up flow piston, which is used when the control valve is used as an up flow softener.

If the control valve is used as a softener or a regenerating filter, a regenerant piston must be attached to the main piston. If the control valve is to be used on system that does not require a regenerant to be added the regenerant piston must be removed.

## SPACER STACK ASSEMBLY

The spacer stack assembly provides the necessary flow passage for water during the different cycles. The all-plastic spacer stack assembly (patent pending) is a one-piece design, which allows the stack to be removed using your fingers.

The exterior of the stack is sealed against the body bore with self-lubricating EPDM o-rings while the interior surface is sealed against the piston using slippery self cleaning directional (oneway) silicone lip seals. The lip seals are red or clear in color and have a special slippery coating so that the piston does not need to be coated or lubricated.

## INJECTOR

The screen, injector and/or injector plug(s) are installed under the injector cap in an easy to access location on top of the valve. The injector cap contains four slots so no water accumulates in the cap. The injector cap is designed to be hand tightened.

Under the injector cap there is an easy to clean removable screen to prevent fouling of the injector. There are two holes under the injector cap labeled "DN" and "UP". The holes will be filled with a plug or an injector.

The plug (#KC113010-IZ) prevents water from traveling through the pathway. The injector lets water pass through the pathway. The self-priming injector increases the velocity of the water, creating a zone of negative pressure that draws in the concentrated liquid regenerant, such as sodium chloride (brine), potassium permanganate, sodium hydroxide, hydrochloric acid, etc. The regenerant blends with the stream of water, which passes

**TABLE 10: Injector Order Information**

PART #	COLOR	TANK DIA.
KC11V3010-1D	RED	9"
KC11V3010-1E	WHITE	10"
KC11V3010-1F	BLUE	12"
KC11V3010-1G	YELLOW	13"
KC11V3010-1J	LT BLUE	16"
KC11V3010-1K	LT GREEN	21"

through the media to regenerate the bed.

The injector provides a consistent regenerant/water mixture ratio over the entire operating pressure range of the control valve. The injector provides good performance in a variety of applications, which may involve elevated drain lines and long regenerant draw lengths. Injectors are chosen by knowing the type, amount, and regenerant flow rate for a particular type of media. The color-coded injectors give different regenerant draw, slow rinse and total flow rates over the pressure range. See Table 10 for color codes.

## REFILL FLOW CONTROL Assembly

The refill flow control assembly consists of a refill flow elbow, refill flow control retainer assembly, refill flow control, poly tube insert and nut assembly. The refill flow control retainer fits in the refill elbow. The refill flow control retainer houses the refill flow control, which controls the flow rate when the regenerant tank is being refilled. The refill flow control is a flexible washer-like part with a small orifice and a precision molded contour that delivers a steady 0.5 gpm regenerant tank refill rate at varying inlet pressures. Refill is accomplished with treated water.

The refill flow control assembly is installed in an easy to access refill elbow located on top of the control valve. The refill flow control assembly is attached to the control valve with a locking clip. The locking clip allows the elbow to rotate 270 degrees so the outlet can be orientated towards the regenerant tank.

## DRAIN LINE FLOW CONTROL/Fitting

The drain line flow control assembly includes a drain line flow control and a fitting. The drain line flow control allows proper media bed expansion by regulating the flow rate to the drain. The drain line flow control is a flexible washer-like part with an orifice and a precision molded contour. The flow rates are within +/- 10% over the pressure range of 1-0 psi to 125 psi. The flexible washer-like parts are identified with three numbers, which correspond to the flow rate in gallons per minute. See Table 11.

The drain line flow control and fitting are located on top of the control valve and replaceable without the use of special tools.

**TABLE 11: Drain Line Flow Control (3/4" Fitting)**

PART #	Number on Backwash Flow Rate Fitting GPM	
KC11V3162-022	22	2.2
KC11V3162-027	27	2.7
KC11V3162-03	32	3.2
KC11V3162-053	53	5.3
KC11V3162-075	75	7.5
KC11V3190-110	110	11

---

## CONTENTS

---

The drain line flow control can be installed in the standard 1/4" drain line elbow, which accommodates 5/8" poly tube or 3/4" NPT drain line connections. The optional nut and poly tube insert for the 3/4" drain line elbow is designed for use with flexible poly tube only. The 3/4" drain line elbow can be rotated 180 degrees so the outlet can be orientated to the nearest drain. The same retainer is used for all drain line flow controls for the 3/4" fitting.

### Water Meter or Meter Plug

The water meter is installed on the outlet side of the control valve. The water meter uses a turbine to total gallons of treated water. The turbine rotates with the flow of water and reports its rate of rotation through Hall-effect 8 circuitry to the printed circuit (PC) board. This rotation permits the PC board to record the total volume of treated water and the flow rate. The small centrally located magnet is shielded from water, which reduces substantially iron-fouling problems with the turbine. The turbine is accurate to within  $\pm 5\%$  over a wide operating flow rate range (0.25 gpm up to control valve maximums) and has a very low pressure drop. Water used for regeneration is not metered. If the control valve is set to prefill the regenerant, water used between the prefill cycle up to the start of the regeneration cycle is metered. If the control valve is in regeneration mode (e.g. a backwash cycle) and there is a water demand that water usage is not metered.

When facing the front of the control valve, the water meter is positioned on the left-hand side of the control valve. Allow sufficient clearance to clean and repair the water meter with out disconnecting the plumbing or disassembling any other parts of the control valve.

A unique feature of this control valve is the ability to display actual water usage for the last 63 days. The values are initially stored as "\_" because it is unknown. As days pass values are stored as "O" for no flow or the actual number of gallons. The counting of the gallons starts at the regeneration time. If no regeneration time can be set (i.e. when the valve is set for immediate regeneration) the counting, of gallons starts at 12 a.m. Day 1 is yesterday, day 2 the day before yesterday, etc. As new values are added the oldest history disappears.

Another unique feature is that the valve automatically calculates a reserve capacity when set up as a softener with "Gallons Capacity" set to "AUTO". The reserve capacity for a given day of the week is the middle value stored for the last three non-trivial water usages (i.e. less than 20 gallons day) in seven-day intervals which is then adjusted either upward or downward depending upon the difference between today's water usage and the estimated reserve capacity.

### Installation Fitting Assemblies

The installation fittings are used to connect the optional bypass or the control to the plumbing system. There are four installation-fitting assemblies available:

1. 1" NPT elbow
2. 3/4" & 1" PVC solvent weld elbow fitting
3. 1" straight brass sweat fitting \*\*
4. 3/4" straight brass sweat Fitting \*\*

Both elbow fittings have a unique drill out feature to allow a 1/4" NPT connection to the inlet and/or outlet which can be

used for a RO feed, test ports, pressure tap ports, etc.

The installation fitting assemblies are sold in pairs and consist of two fittings, two nuts, two split rings and two o-rings. The installation fitting assemblies and the bypass valve are sold separately from the control valve.

### Bypass Valve

The bypass valve is typically used to isolate the control valve from the plumbing system's water pressure in order to perform control valve repairs or maintenance. The W100SM bypass valve is particularly unique in the water treatment industry due to its versatility and state of the art design features. The 1" full flow bypass valve incorporates four positions including a diagnostic position that allows service personnel to work on a pressurized system while still providing untreated bypass water to the facility or residence. Its completely non-metallic, all plastic design allows for easy access and serviceability without the need for tools.

The bypass body and rotors are glass filled Noryl and the nuts and caps are glass filled polypropylene. All seals are self-lubricating EPDM to help prevent valve seizing after long periods of nonuse. Internal o-rings can easily be replaced if service is required.

The bypass consists of two interchangeable plug valves that are operated independently by red arrow shaped handles. The handles identify the flow direction of the water. The plug valves enable the bypass valve to operate in four positions.

- 1. Normal Operation Position:** The inlet and outlet handles point in the direction of flow indicated by the engraved arrows on the control valve. Water flows through the control valve during normal operation and this position also allows the control valve to isolate the media bed during the regeneration cycle. (See Figure 17)
- 2. Bypass Position:** The inlet and outlet handles point to the center of the bypass, the control valve is isolated from the water pressure contained in the plumbing system. Untreated water is supplied to the plumbing system. (See Figure 18)
- 3. Diagnostic Position:** The inlet handle points in the direction of flow and the outlet handle points to the center of bypass valve, system water pressure is allowed to the control valve and the plumbing system while not allowing water to exit from the control valve to the plumbing. (See Figure 19)
- 4. Shut Off Position:** The inlet handle points to the center of the bypass valve and the outlet handle points in the direction of flow, the water is shut off to the plumbing systems. If water is available on the outlet side of the softener it is an indication of water bypass around the system (i.e. a plumbing connection somewhere in the building bypasses the system). (See Figure 20)

\* Some semiconductor materials exhibit a phenomenon in the presence of a magnetic field that is adaptable to sensing devices. When a current is passed through one pair of wires attached to a semiconductor, another pair of wires properly attached and oriented with respect to the semiconductor will develop a voltage proportional to the magnetic field present and the current in the other pair of wires. Holding the exiting current constant and moving a permanent magnet near the semiconductor produces a voltage output proportional to the movement of the magnet. Hall-effect devices provide a high-speed response, excellent temperature stability and no physical contact.

\*\* Has not been tested for compliance with California Proposition 65 so this fitting should not be installed in California.

---

## SYSTEM COMPONENTS DESCRIBED

---

NORMAL OPERATION

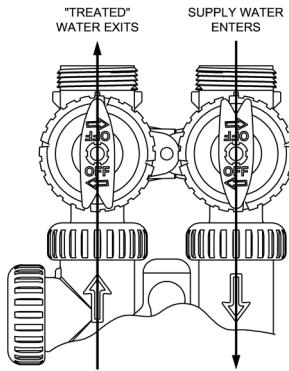

Figure 17:

BYPASS OPERATION

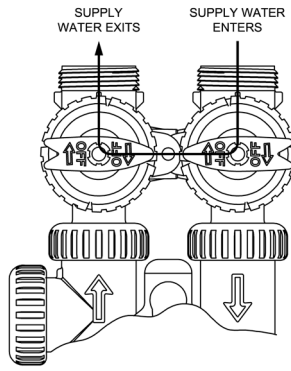

Figure 18:

DIAGNOSTIC MODE

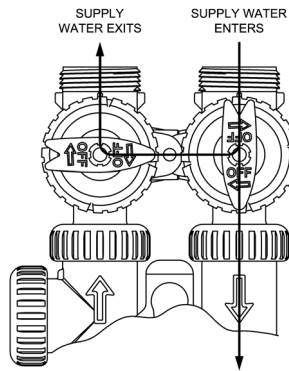

Figure 19

SHUT OFF MODE

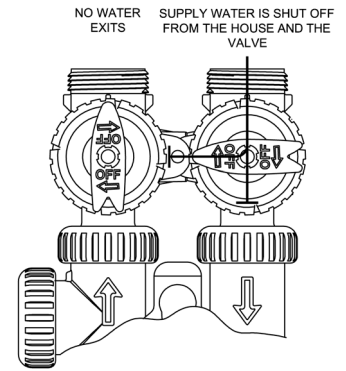

Figure 20::

---

## SYSTEM COMPONENTS DESCRIBED

---

### Service Instructions

#### DRIVE ASSEMBLY

Remove the valve cover to access the drive assembly.

Disconnect the power source plug (black wire) from the PC board prior to disconnecting the motor or water meter plugs from the PC board. The motor plug connects to the two-pin jack on the left-hand side of the PC board. The power source plug connects to the four-pin jack. The four-pin jack is between the two-pin and three-pin jacks. The water meter plug (gray wire) connects to the three.

The PC board can be removed separately from the drive bracket but it is not recommended. Do not attempt to remove the display panel from the PC board. Handle the board by the edges. To remove the PC board from the drive bracket, unplug the power, water meter and motor plugs from the PC board. Lift the middle latch along the top of the drive bracket while pulling outward on the top of the PC board. The drive bracket has two plastic pins that fit into the holes on the lower edge of the PC board. Once the PC board is tilted about 45° from the drive bracket it can be lifted off of these pins. To reinstall the PC board, position the lower edge of the PC board so that the holes in the PC board line up with the plastic pins. Push the top of the PC board towards the valve until it snaps under the middle latch, weave the power and water meter wires into the holders and reconnect the motor water meter and power plugs.

The drive bracket must be removed to access the drive cap assembly and pistons or the drive gear cover. It is not necessary to remove the PC board from the drive bracket to remove the drive bracket. To remove the drive bracket start by removing the plugs for the power source and the water meter. Unweave the wires from the side holders. Two tabs on the top of the drive back plate hold the drive bracket in place. Simultaneously lift the two tabs and gently ease the top of the drive bracket towards your body. The lower edge of the drive bracket has two notches that rest on the drive back plate. Lift up and outward on the drive bracket to disengage the notches.

To reassemble seat the bottom of the drive bracket so the notches are engaged at the bottom of the drive back plate. Push the top of the drive bracket towards the two latches. The drive bracket may have to be lifted slightly to let the threaded piston rod pass through the hole in the drive bracket. Maintain a slight engaging force on top of the drive bracket while deflecting the bracket slightly to the left by pressing on the side of the upper right corner. This helps the drive gears mesh with the drive cap assembly. The drive bracket is properly seated when it snaps under the latches on the drive back plate. If resistance is felt before latching, then notches are not fully engaged, the piston rod is not in hole, the wires are jammed between the drive bracket and drive back plate, or the gear is not engaging the drive cap assembly.

To inspect drive gears, the drive gear cover needs to be removed. The drive gear cover is held in place on the drive bracket by three clips. The largest of the three clips is always orientated to the bottom of the drive bracket. Before trying to remove the drive gear cover, the drive bracket must be removed from the drive back plate. The drive gear cover can be removed from the drive bracket without removing the motor or the PC board. Simultaneously, push in and down on the large clip at the bottom and the clip on the left-hand side of the drive bracket behind the PC board. Keep your other fingers behind the drive gear cover so the drive gears do not drop on the ground. Replace broken or damaged drive gears. Do not lubricate any of the gears. Avoid getting any foreign matter on the reflective coating because dirt or oils may interfere with pulse counting.

The drive gear cover only fits on one way, with the large clip orientated towards the bottom. If all three clips are outside of the gear shroud on the drive bracket the drive gear cover slips easily into place.

The drive bracket does not need to be removed from the drive plate if the motor needs to be removed. To remove the motor, disconnect the power and motor plugs from the jacks on the PC

---

## SERVICE INSTRUCTIONS

---

board. Move the spring clip loop to the right and hold. Rotate the motor at least a 1/4 turn in either direction before gently pulling on the wire connectors to remove the motor. Pulling directly on the wires without rotating the motor may break the wires off the motor.

Replace the motor if necessary. Do not lubricate the motor or the gears. When reinstalling the motor gently turn the motor while inserting so that the gear on the motor meshes with the gears under the drive gear cover and the small plastic bulge engages one of the slots on the motor housing. Reconnect the motor plug to the two-pronged jack on the lower left-hand side of the PC board. If motor will not easily engage with drive gear when reinstalling, lift and slightly rotate motor before reinserting.

Replace the valve cover. After completing any valve maintenance, press and hold NEXT and REGEN buttons for 3 seconds or unplug power source jack (black wire) and plug back in. This resets the electronics and establishes the service piston position. The display should flash all wording, then flash the software version (e.g. 154) and then reset the valve to the service position.

### DRIVE CAP ASSEMBLY, MAIN PISTON AND REGENERANT PISTON

The drive assembly must be removed to access the drive cap assembly. The drive cap assembly must be removed to access the piston(s). The drive cap assembly is threaded into the control valve body and seals with an o-ring. To remove the drive cap assembly, use the special plastic wrench or insert a 1/4" to 1" flat bladed screwdriver into one of the slots around the top 2" of the drive cap assembly so it engages the notches molded into the drive back plate around the top 2" of the piston cavity. See Figure 5. The notches are visible through the holes. Lever the screwdriver so the drive cap assembly turns counter clockwise. Once loosened unscrew the drive cap assembly by hand and pull straight out.

The drive cap assembly contains the drive cap, the main drive

vinegar or replace the main piston.

Reattach the main piston to the drive cap assembly. Reattach the regenerant piston (if needed) to the main piston. Do not lubricate the piston rod, main piston or regenerant piston. Lubricant will adversely affect the red or clear lip seals. Reinsert the drive cap assembly and piston into the spacer stack assembly and hand tighten the drive cap assembly. Continue to tighten the drive cap assembly using a screwdriver as a ratchet until the black oring on the spacer stack assembly is no longer visible through the drain port. Excessive force can break the notches molded into the drive back plate. Make certain that the main drive gear still turns freely. The exact position of the piston is not important as long as the main drive gear turns freely.

Reattach the drive assembly to the control valve and connect all plugs. After completing any valve maintenance, press and hold NEXT and REGEN buttons for 3 seconds or unplug power source jack (black wire) and plug back in. This resets the electronics and establishes the service piston position. The display should flash all wording, then flash the software version (e.g. 154) and then reset the valve to the service position.

### SPACER STACK ASSEMBLY

To access the spacer stack assembly remove the drive assembly, drive cap assembly and piston. The spacer stack assembly can be removed easily without tools by using thumb and forefinger. Inspect the black o-rings and red or clear lip seals for wear or damage. Replace the entire stack if necessary. The spacer stack assembly has been 100% tested at the factory to insure proper orientation of one-way seals. Do not disassemble the stack.

The spacer stack assembly may be chemically cleaned (dilute sodium bisulfite or vinegar) or wiped with a soft cloth.

The spacer stack assembly can be pushed in to the control valve body bore by hand. Since the spacer stack assembly can be compressed it is easier to use a blunt object (5/8" to 1-1/8" in diameter) to push the center of the assembly into the control valve body. The assembly is properly seated when at least four threads are exposed (approximately 5/8"). Do not force the spacer stack assembly in. The control valve body bore interior can be lubricated with silicone to allow for easy insertion of the entire stack. Do not use silicone or any other type of lubricant on the red or clear lip seals or the piston.

Reattach the drive cap assembly, and piston(s) and the drive assembly.

After completing any valve maintenance, press and hold NEXT and REGEN buttons for 3 seconds or unplug power source jack (black wire) and plug back in. This resets the electronics and establishes the service piston position. The display should flash all wording, then flash the software version (e.g. 154) and then reset the valve to the service position.

### INJECTOR CAP, SCREEN, INJECTOR PLUG AND INJECTOR

Unscrew the injector cap and lift off. Loosen cap with special plastic wrench or pliers if necessary. Attached to the injector cap is a screen. Remove the screen and clean if fouled.

### Missing Photo

Figure 21: To remove drive cap

gear, drive cap spline, piston rod and various other parts that should not be disassembled in the field. The only replaceable part on the drive cap assembly is the o-ring. Attached to the drive cap assembly is the main piston (downflow or upflow) and if a regenerant is used, a regenerant piston.

The regenerant piston (the small diameter one behind the main piston) is removed from the main piston by unsnapping it from its latch. Chemically clean in dilute sodium bisulfite or vinegar or replace the regenerant piston if needed. To remove the main-downflow or upflow piston fully extend the piston rod and then unsnap the main piston from its latch by pressing on the side with the number. Chemically clean in dilute sodium bisulfite or

---

## CONTENTS

---

The plug and/or injector can be pried out with a small screwdriver. The plug can be wiped clean. If the plug leaks replace the entire plug. The injector consists of a throat and a nozzle. Chemically clean the injector with vinegar or sodium bisulfite. The holes can be blown out with air. Both pieces have small diameter holes that control the flow rates of water to insure that the proper concentration of regenerant is used. Sharp objects, which can score the plastic, should not be used to clean the injector. Scoring the injector or increasing the diameter of the hole could change the operating parameters of the injector. Two holes are labeled DN and UP. Check for compliance with one of the following:

- a. For downflow systems, the appropriate size injector is located in the "DN" hole, a plug is in the "UP" hole and the piston is a combination of the downflow main piston and the regenerant piston;
- b. For upflow systems, the appropriate size injector is located in the "UP" hole, a plug is in the "DN" hole and the piston is a combination of the upflow main piston and the regenerant piston; or
- c. For backwash only systems, a plug is in the "DN" hole and in the "UP" hole, and the piston only has a downflow main piston (the regenerant piston must be removed) and a plug is in the refill flow control position.

Push the plug(s) and/or injectors firmly in place, replace the screen and hand tighten the injector cap.

### REFILL FLOW CONTROL ASSEMBLY OR REFILL PORT PLUG

To clean or replace the refill flow control, pull out the elbow-locking clip and then pull straight up on the elbow. Replace the elbow-locking clip in the slot so that it is not misplaced. Twist to remove the white flow control retainer. The flow control can be removed by prying upward through the side slots of the retainer with a small blade flat screwdriver.

Chemically clean the flow control or the white flow control retainer using dilute sodium bisulfite or vinegar. Do not use a wire brush. If necessary, replace the flow control o-ring on the flow control retainer, or the o-ring on the elbow.

Reseat the flow control so the rounded end is visible in the flow control. Reseat the white flow control retainer by pushing the retainer into the elbow until the o-ring seats. Remove locking clip, push down on elbow to reseat and insert locking clip.

Do not use Vaseline, oils, or other unacceptable lubricants on o-rings. A silicon lubricant may be used on the o-ring on elbow or the white retainer.

### WATER METER OR METER PLUG

The water meter assembly is connected to the PC board by a wire. If the entire water meter assembly is to be replaced, remove the control valve cover and remove the power source and water meter plugs from the PC board. Unlatch the drive assembly and lean it forward. Unthread the water meter wire from the side of the drive assembly and through the drive back plate. To reinstall, rethread the water meter wire through the drive back plate and the side of the drive assembly. Reattach the drive assembly and the water meter and power plugs.

If no water meter wire is visible, then a plug is installed not a

water meter.

The water meter wire does not need to be removed from the PC board if the water meter is only being inspected and cleaned.

To remove the water meter assembly, unscrew the meter cap on the left side of the control valve. Pliers may be used to unscrew the nut if necessary.

With the nut removed, a slot at the top of the water meter is visible. Twist a flat blade screwdriver in the slot between the control valve body and the meter. When the meter is part way out it is easy to remove the water meter from the housing. Once the water meter is removed from the control valve body, use your fingers to gently pull forward on the turbine to remove it from the shaft.

Do not use a wire brush to clean. Wipe with a clean cloth or chemically clean in dilute sodium bisulfite or vinegar. The turbine can be immersed in the chemical. Do not immerse electronics. If the turbine is scored or damaged or the bearings on the turbine are worn replace the turbine.

Do not lubricate the turbine shaft. The turbine shaft bearings are pre-lubricated. Do not use Vaseline, oils or other unacceptable lubricants on the o-ring. A silicon lubricant may be used on the black o-ring.

Snap the turbine on the shaft and reinsert the water meter into the side slot. Hand tighten the nut. Do not use a pipe wrench to tighten nut.

### BYPASS VALVE

The working parts of the bypass valve are the rotor assemblies that are contained under the bypass valve caps. Before working on the rotors, make sure the system is depressurized. Turn the red arrow shaped handles towards the center of the bypass valve and back to the arrow direction several times to ensure rotor is turning freely.

The nuts and caps are designed to be unscrewed or tightened by hand. If necessary a pair of pliers can be used to unscrew the nut or cap. Do not use a pipe wrench to tighten or loosen nuts or caps. Do not place screwdriver in slots on caps and/or tap with a hammer. To access the rotor, unscrew the cap and lift the cap, rotor and handle out as one unit. Twisting the unit as you pull it out will help to remove it more easily. There are three o-rings: one under the rotor cap, one on the rotor stem and the rotor seal. Replace worn o-rings. Clean rotor. Reinstall rotor.

When reinstalling the red arrow handles be sure that:

1. O-rings on both rotors face to the right when being viewed from the front of the control valve when the handle pointers are lined up with the control valve body arrows; or
2. Arrows point toward each other in the bypass position.

Since the handles can be pulled off, they could be accidentally reinstalled 180° from their correct orientation. To install the red arrow handles correctly, keep the handles pointed in the same direction as the arrows engraved on the control valve body while tightening the bypass valve caps.

After completing, any valve maintenance, press and hold NEXT and REGEN buttons for 3 seconds or unplug power source jack (black wire) and plug back in. This resets the electronics and establishes the service piston position. The display should flash all wording then flash the software version (e.g. 154) and then reset the valve to the service position.

# DRAWING AND PART NUMBERS

## BRINE TANK AND SOFTENER TANK

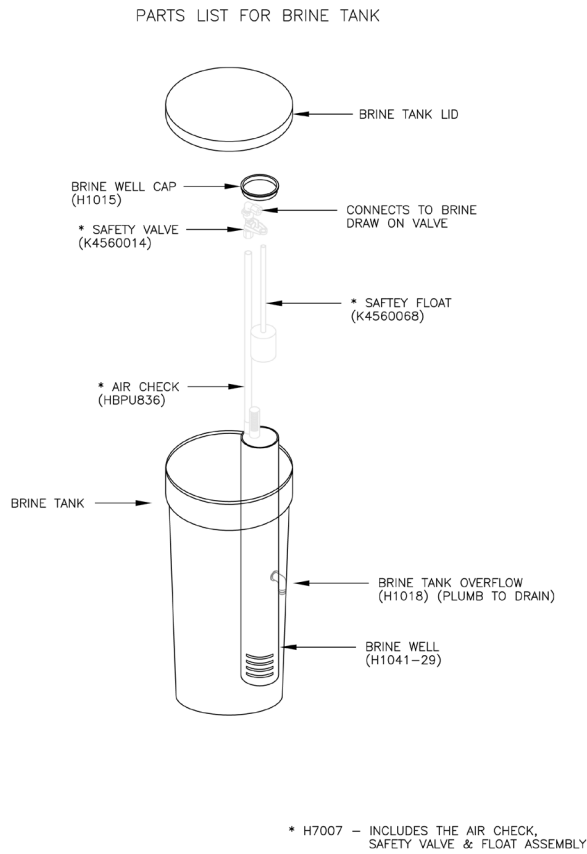

Figure 17

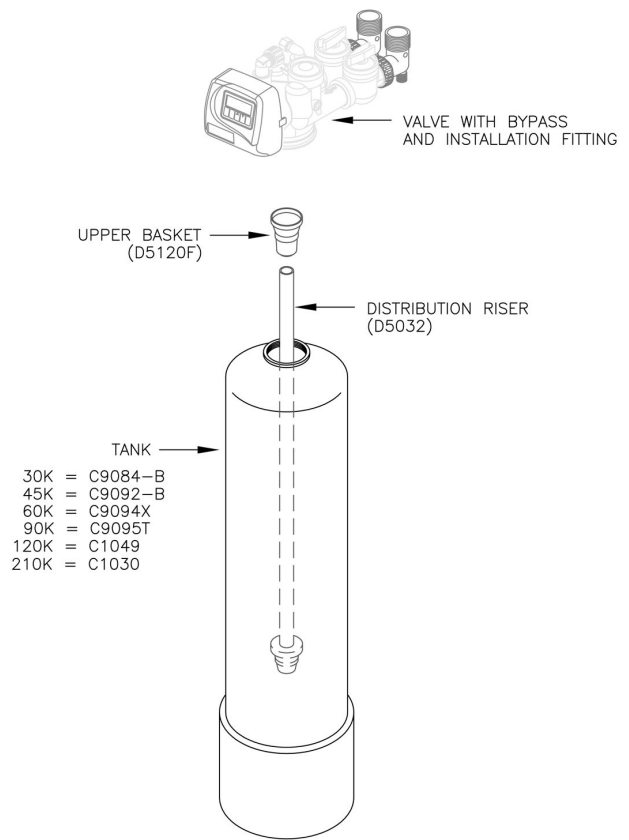
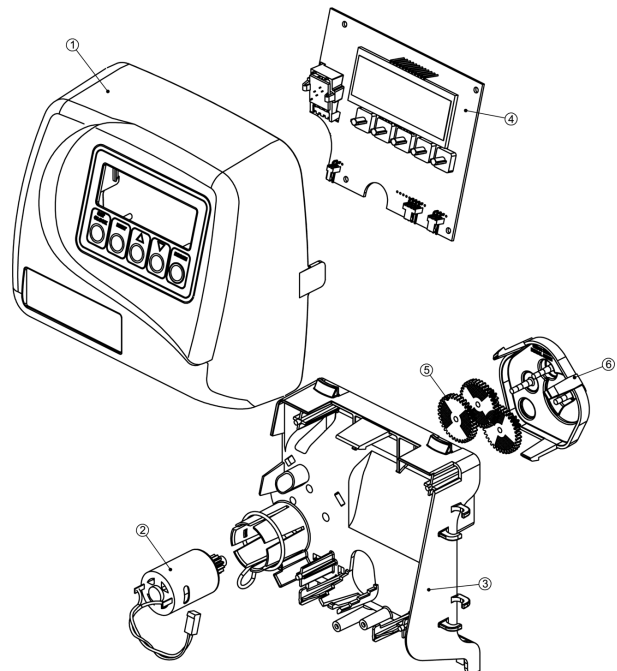

Figure 18

## FRONT COVER AND DRIVE ASSEMBLY

Drawing No.	Order No.	Description	Qty.
1	KC11V317501	W100SM Front Cover ASY 1	
2	KC12V3107-01	W100SM Motor	1
3	KC12F3106-01	W100SM Drive Bracket & Spring Clip	1
4	KC12V3108	W100SM PC Board	1
5	KC12V3110	W100SM Drive Gear 12x36	3
6	KC12V3109	W100SM Drive Gear Cover	1
	KC12V3002	W100SM Drive ASY	*
Not Shown	KC11V3186	W100SM Transformer 110V-12V	1

\*Drawing number parts 2 through 6 may be purchased as a complete assembly, part V3002.



## CONTENTS

### DRIVE CAP ASSEMBLY, DOWNFLOW PISTON, UPFLOW PISTON, REGENERANT PISTON AND SPACER STACK ASSEMBLY

Drawing No.	Order No.	Description	Qty.
1	KC12V3005	W100SM Spacer Stack Assembly	1
2	KC12V3004	Drive Cap ASY	1
3	KC12V3135	O-ring 228	1
4	KC12V3011	W100SM Piston Downflow ASY	1
5	KC12V3174	W100SM Regenerant Piston	3
6	KC12V3180	O-ring 337	1

Note: The regenerant piston is not used in backwash only applications.

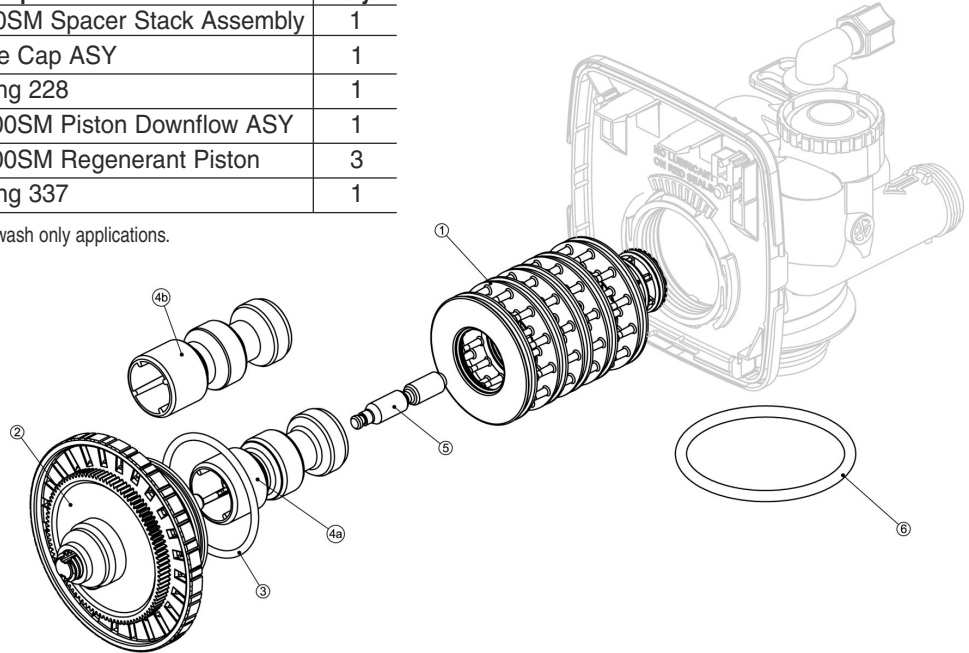

### INJECTOR CAP, INJECTOR SCREEN, INJECTOR, PLUG AND O-RING

Drawing No.	Order No.	Description	Qty.
1	KC12V3176	Injector Cap	1
2	KC12V3152	O-ring 135	1
3	KC12V3177	Injector Screen	1
4	KC12V3010-12	W100SM Injector ASY Z Plug	1
5	KC12V3010-10	W100SM Injector ASY D Red	1
	KC12V3010-IE	W100SM Injector ASY E White	1
Not Shown	KC12V3170	O-ring 011	*
Not Shown	KC12V3171	O-ring 013	*

\*The injector plug and the injector each contain one 011 (lower) and one 013 (upper) o-ring.

Note: For upflow position, injector is located in the up hole and injector plug in the down hole. For a filter that only backwashes injector plugs are located in both holes.

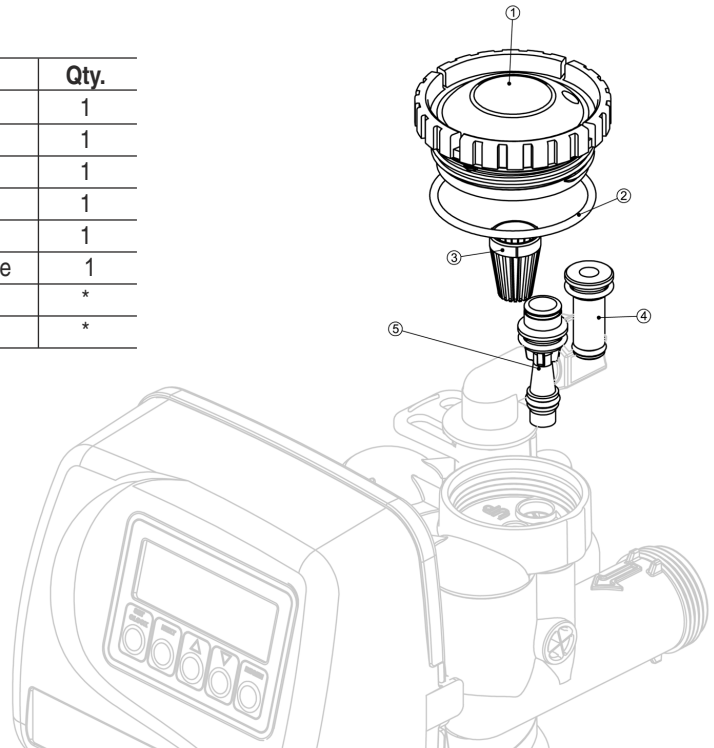

## DRAWING AND PART NUMBERS

Drawing No.	Order No.	Description	Qty.
1	KC12V3195-01	W100SM Refill Port Plug ASY	**
2	KC12H4615	Elbow Locking Clip	1
3	KC12JCP-P-6	Polytube insert 3/8	1
4	KC12JCPG-6PBLK	Nut 3/8	1
5	KC12H4613	Elbow Cap 3/8	1
6	KC12V3163	O-ring 019	1
7	KC12V3165-01	W100SM RFC Retainer ASY	1
8	KC12V3182	W100SM RFC	1

\*Assembly includes WS1 RFC.

\*\*This part is required for backwash only systems.

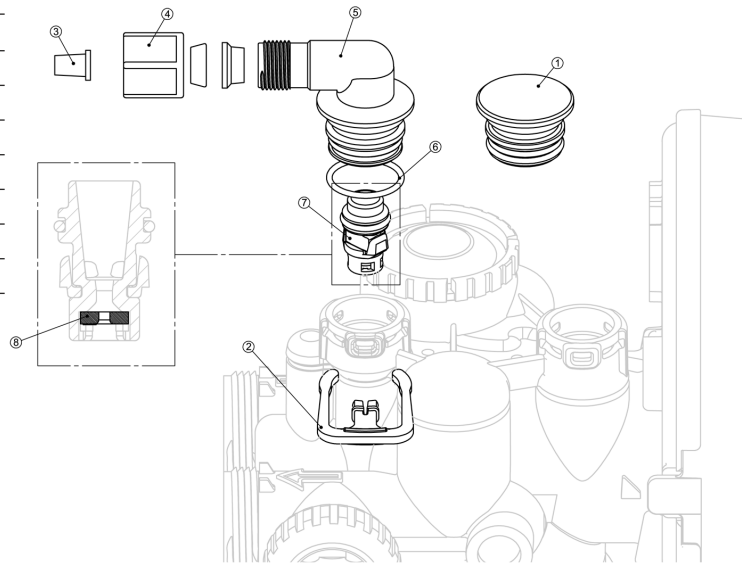

## DRAIN LINE - 3/4"

Drawing No.	Order No.	Description	Qty.
1	KC12H4615	Elbow Locking Clip	1
2	KC12PKP10T58	Polytube insert 5/8	Option
3	KC12V3192	W100SM Nut 3/4 Drain Elbow	Option
4	KC12V3158-01	W100SM Drain Elbow 3/4 Male ASY	1
5	KC12V3163	O-ring 019	1
6	KC12V3159-01	W100SM DLFC Retainer ASY	1
7	KC12V3162-022	W100SM DLFC 2.2 gpm for 3/4	*
	KC12V3162-027	W100SM DLFC 2.7 gpm for	

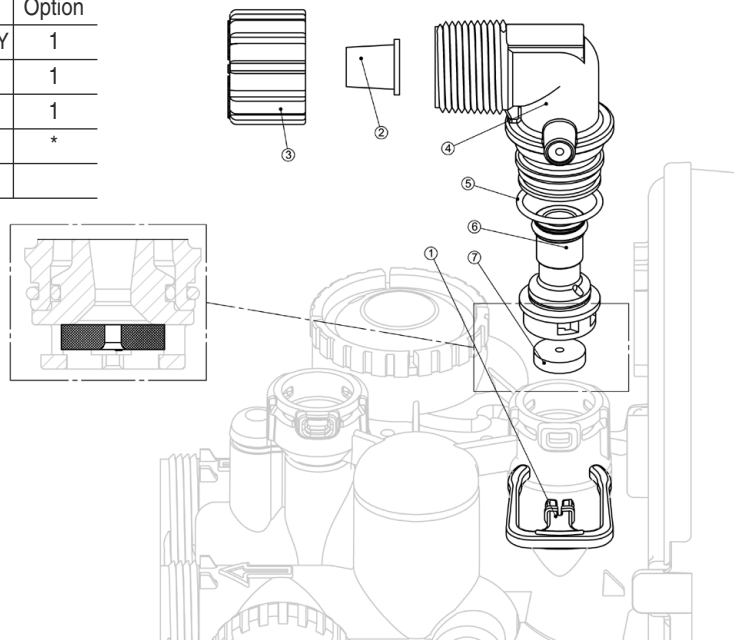

# DRAWING AND PART NUMBERS

## WATER METER AND METER PLUG

Drawing No.	Order No.	Description	Qty.
1	KC12V3151	W100SM Nut 1" QC	1
2	KC12V3003	W100SM Meter ASY	1
3	KC12V3118-01	W100SM Turbine ASY	1
4	KC12V3105	O-ring 215	1
5	KC12V3003-01	W100SM Meter Plug ASY	1

\* Order number KC12V3003 includes KC12V3118-01 and KC12V3105.

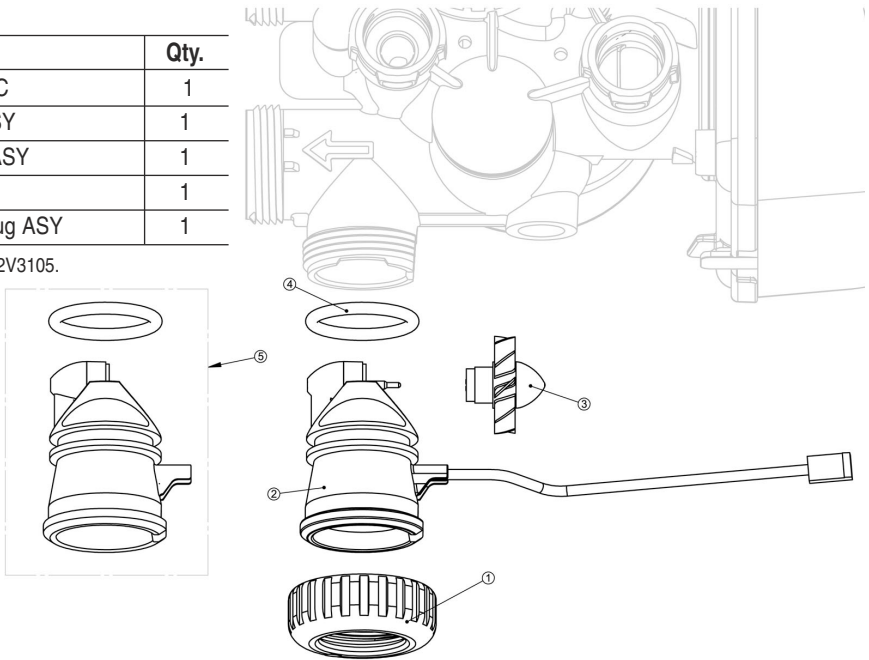

## INSTALLATION FITTING ASSEMBLIES

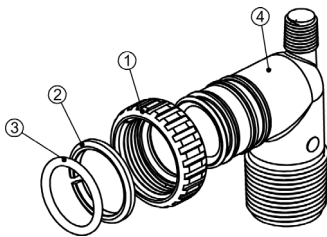

Drawing No.	Order No.	Description	Qty.
1	KC12V3151	W100SM Nut 1" Quick Connect	2
2	KC12V3150	W100SM Split Ring	2
3	KC12V3105	O-ring 215	2
4	KC12V3149	W100SM Fitting 1" PVC Male NPT Elbow	2

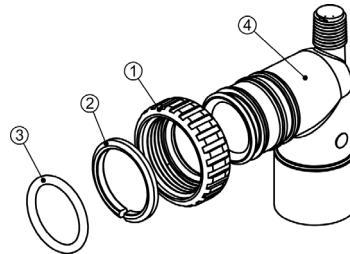

Drawing No.	Order No.	Description	Qty.
1	KC12V3151	W100SM Nut 1" Quick Connect	2
2	KC12V3150	W100SM Split Ring	2
3	KC12V3105	O-ring 215	2
4	KC12V3189	W100SM Fitting 3/4" & 1" PVC Solvent 90	2

Drawing No.	Order No.	Description	Qty.
1	KC12V3151	W100SM Nut 1" Quick Connect	2
2	KC12V3150	W100SM Split Ring	2
3	KC12V3105	O-ring 215	2
4	KC12V3188	W100SM Fitting 1" Brass Sweat	2

Drawing No.	Order No.	Description	Qty.
1	KC12V3151	W100SM Nut 1" Quick Connect	2
2	KC12V3150	W100SM Split Ring	2
3	KC12V3105	O-ring 215	2
4	KC12V3188-01	W100SM Fitting 3/4" Brass Sweat	2

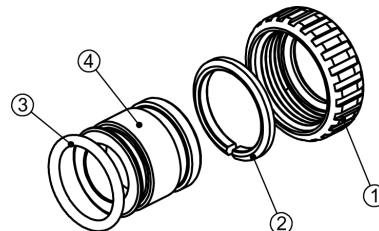
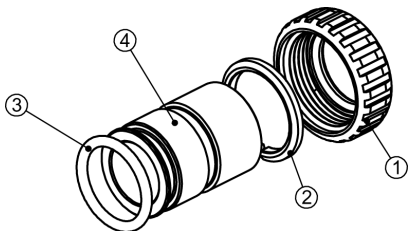

# DRAWING AND PART NUMBERS

## BYPASS VALVE

Drawing No.	Order No.	Description	Qty.
1	KC12V3151	W100SM Nut 1" Quick Connect	2
2	KC12V3150	W100SM Split Ring	2
3	KC12V3105	O-ring 215	2
4	KC12V3145	W100SM Bypass 1" Rotor	2
5	KC12V3146	W100SM Bypass Cap	2
6	KC12V3147	W100SM Bypass Handle	2
7	KC12V3148	W100SM Bypass Rotor Seal Retainer	2
8	KC12V3152	O-ring 135	2
9	KC12V3155	O-ring 112	2
10	KC12V3156	O-ring 214	2

(Not Shown) Order No.KC12 V3191-01. Description: WS100sm Bypass Vertical Adapter Assembl

Order No.	Description	Qty.
KC12V3151	W100SM Nut 1" Quick Connect	1
KC12V3150	W100SM Split Ring	1
KC12V3105	O-ring 215	1
KC11V3191-01	W100SM Bypass Vertical Adapter Assembly	1

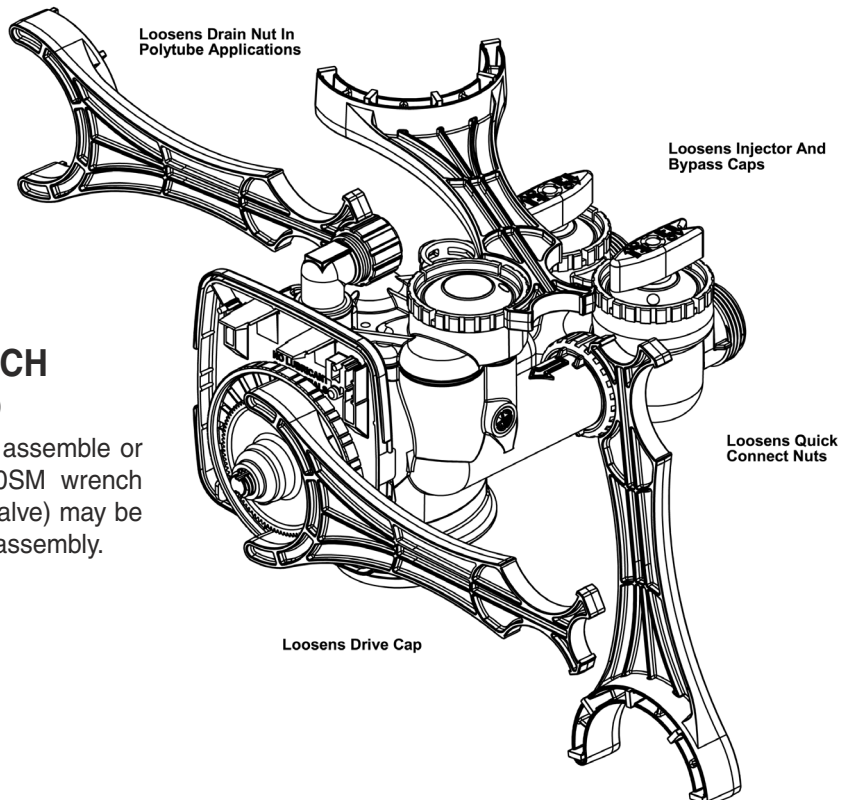
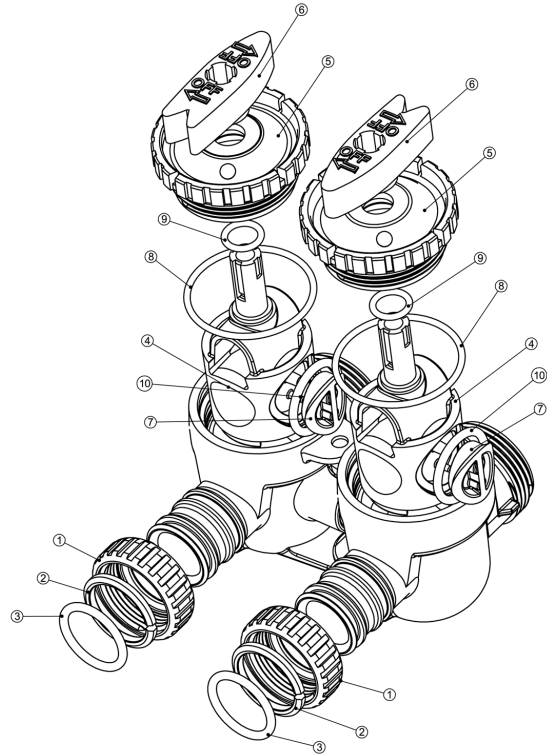

### W100SM WRENCH

(Order No. KC12V3193)

Although no tools are necessary to assemble or disassemble the valve, the WS100SM wrench (shown in various positions on the valve) may be purchased to aid in assemble or disassembly.

# DRAWING AND PART NUMBERS

## flow diagram...service

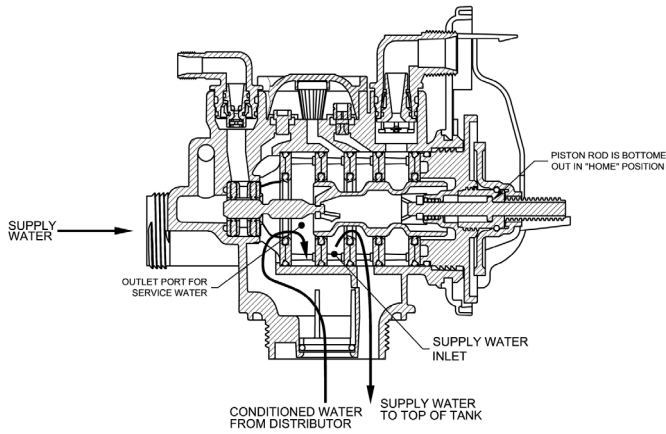

## flow diagram...rinse

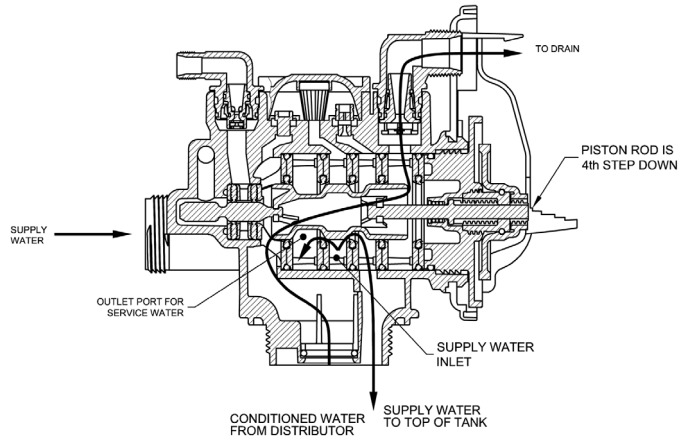

## flow diagram...backwash

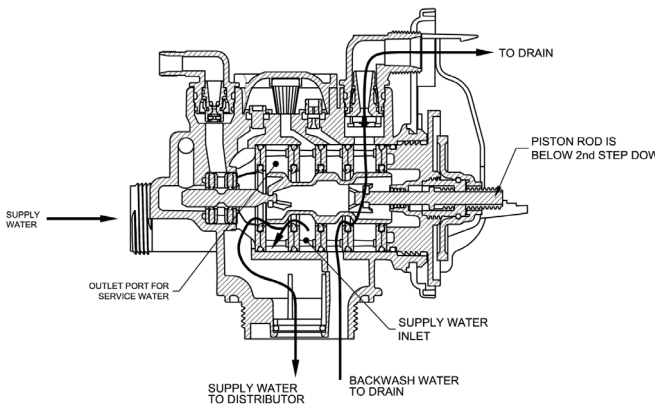

## flow diagram...fill

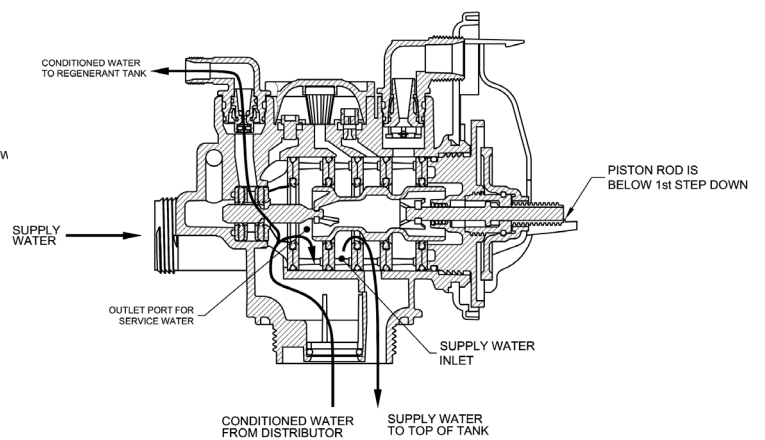

## flow diagram...downflow brine

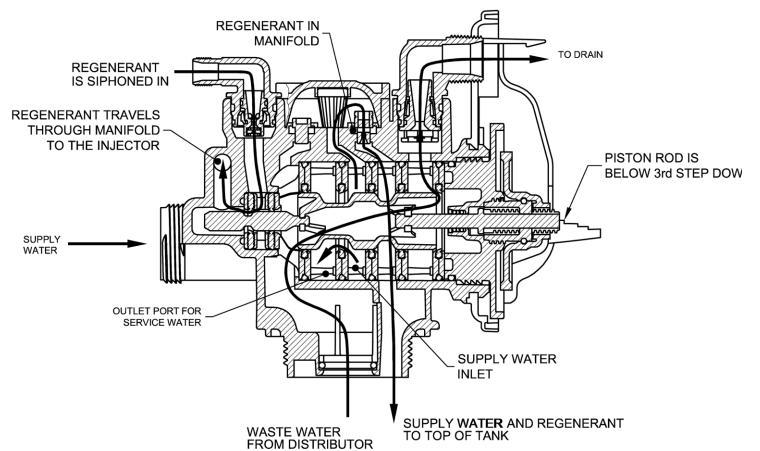

## TROUBLESHOOTING

### System Troubleshooting

PROBLEM	CAUSE	CORRECTION
1. Loss of Resin	A. Broken distribution tube	A. Replace distribution tube.
	B. Inlet/Outlet connection reversed.	B. Reconnect inlet/outlet connection properly.
2. Softener fails to regenerate.	A. Electrical service to unit has been interrupted.	A. Assure permanent electrical service (check fuse, plug, pull chain or switch.
	B. Timer is defective.	B. Replace timer.
	C. Power failure.	C. Reset time of day.
3. Hard Water	A. Bypass valve is open.	A. Close bypass valve.
	B. No salt in brine tank.	B. Add salt to brine tank and maintain salt level abovewater level.
	C. Injector screen plugged.	C. Clean injector screen.
	D. Insufficient water flowing into brine tank.	D. Check brine tank fill time and clean brine line flow control if plugged.
	E. Hot water tank hardness,	E. Repeated flushing of the hot water tank is required.
	F. Leak at distributor tube.	F. Make sure distributor tube is not cracked. Check "O" Ring and tube pilot.
	G. Internal valve leaking.	G. Replace seals and spacers and or piston.
4. Unit used too much salt.	A. Improper salt setting.	A. Check salt usage and sat setting.
	B. Excessive water in brine tank.	B. See Problem No. 8.
5. Loss of water pressure.	A. Iron buildup in line to water conditioner.	A. Clean line to water conditioner.
	B. Iron buildup in water conditioner.	B. Clear control and add mineral cleaner and increase regeneration frequency.
	C. Inlet of control plugged due to foreign material broken loose from pipes by recent work done on plumbing system.	C. Remove piston and clean control.
6. Loss of mineral through drain line.	A. Air in water system.	A. Assure that well system has proper air eliminator control. Check for dry well condition.
7. Iron in conditioned water.	A. Fouled mineral bed.	A. Check backwash, brine draw, and brine tank fill. Increase frequency of regeneration. Increase backwash time.

## TROUBLESHOOTING

### System Troubleshooting (continued)

PROBLEM	CAUSE	CORRECTION
8. Excessive water in brine tank.	A. Plugged drain line flow control.	A. Clean flow control.
	B. Plugged injector system.	B. Clean injector and screen.
	C. Foreign material in brine valve.	C. Replace timer.
	D. Defective controller.	D. Replace controller.
	E. Foreign material in brine line flow control.	E. Clean brine line flow control.
9. Softener fails to draw brine.	A. Drain line flow control is plugged.	A. Clean drain line flow control
	B. Injector is plugged.	B. Clean injector.
	C. Injector screen plugged.	C. Clean screen.
	D. Line pressure is too low.	D. Increase line pressure to 20 P.S.I.
	E. Internal control leak.	E. Change seals, spacers, and piston assembly.
10. Control cycles continuously.	A. Broken or shorted switch,	A. Determine if switch or timer is faulty and replace it, or replace complete power head.
11. Drain flows continuously.	A. Piston is not positioned correctly when in service.	A. Check timer program and positioning of control. Replace power head assembly if not positioning properly.
	B. Foreign material in control.	B. Remove power head assembly and inspect bore. Remove foreign material and check control in various regeneration positions.
	C. Internal control leak	C. Replace seals and piston assembly.
12. Brine tank fills during brine step.	A. Clogged drain.	A. Replace drain line.
	B. Internal piston seal leaks.	B. Replace seals in piston assembly.

**See**  
**Troubleshooting**  
**Programming**

(next page)

## TROUBLESHOOTING

### Troubleshooting Programming

PROBLEM	POSSIBLE CAUSE	SOLUTION
1. Timer does not display time of day	a. Transformer unplugged	a. Connect power
	b. No electric power at outlet	b. Repair outlet or use working outlet.
	c. Defective transformer	c. Replace transformer
	d. Defective PC board	d. Replace PC board
2. Timer does not display correct time of day	a. Switched outlet	a. Use uninterrupted outlet
	b. Power outage	b. Reset time of day
	c. Defective PC board	c. Replace PC board
3. No softening display when water is flowing	a. Bypass valve in bypass position	a. Put bypass valve in service position
	c. Restricted/stalled meter turbine	c. Remove meter and check for rotation or foreign material
	d. Defective meter	d. Replace meter
	e. Defective PC board	e. Replace PC board
4. Control valve regenerates at wrong time of day of day	a. Power outages	a. Reset control valve to correct time
	b. Time of day not set correctly	b. Reset to correct time of day
	c. Time of regeneration incorrect	c. Reset regeneration time
	d. Control valve set at "on 0" (immediate regeneration)	d. Check control valve set-up procedure regeneration time option
	e. Control valve set at NORMAL on 0	e. Check control valve set-up procedure regeneration time option
5. ERROR followed by code number  Error Code 1001 -Unable to recognize start of regeneration  Error Code 1002 - Unexpected stall  Error Code 1003 - Motor ran to long, timed out trying to reach next cycle position  Error Code 1004 - Motor ran to long, timed out trying to reach home position  If other Error Codes display contact the factory.	a. Control valve has just been serviced	a. Press NEXT and REGEN for 3 seconds or unplug power source Jack (black wire) and plug back in to reset control valve
	b. Foreign matter is lodged in control valve.	b. Check piston and spacer stack assembly for foreign matter.
	c. High drive forces on piston	c. Replace piston(s) and spacer stack assembled.
	d. Control valve piston not in home position	d. Press NEXT and REGEN for 3 seconds or unplug power source jack (black wire) and plug back in to reset control valve
	e. Motor not inserted fully to engage pinion, motor wires broken or disconnected, motor failure	e. Check motor and wiring. Replace motor if necessary
	f. Drive gear label dirty or damaged missing or broken gear	f. Replace or clean drive gear
	g. Drive bracket incorrectly aligned to back plate	g. Reseat drive bracket properly
	h. PC board is damaged or defective	h. Replace PC board
	i. PC board incorrectly aligned to drive bracket	i. Ensure PC board is correctly snapped on to drive

## CONTENTS

### Troubleshooting Programming (continued)

PROBLEM	POSSIBLE CAUSE	SOLUTION
6. Control valve stalled in regeneration	a. Motor not operating	a. Replace motor
	b. No electric power at outlet	b. Repair outlet or use working outlet
	c. Defective transformer	c. Replace transformer
	d. Defective PC board	d. Replace PC board
	e. Broken drive gear or drive cap assembly	e. Replace drive gear or drive cap assembly
	f. Broken piston retainer	f. Replace drive cap assembly
	g. Broken main or regenerant piston	g. Replace main or regenerant piston
7. Control valve does not regenerate when REGEN button is pressed.	a. Transformer unplugged	a. Connect transformer
	b. No electric power at outlet	b. Repair outlet or use working outlet
	c. Broken drive gear or drive cap	c. Replace drive gear or drive cap assembly
	d. Defective PC board	d. Replace PC board
8. Control valve does not regenerate automatically but does when REGEN button is depressed	a. By-pass valve in bypass position	a. Put control valve in service position
	b. Meter connection disconnected	b. Connect meter to PC board
	c. Restricted/stalled meter turbine	c. Remove meter and check for rotation or foreign matter
	d. Defective meter	d. Replace meter
	e. Defective PC board	e. Replace PC board
	f. Set-up error	f. Check control valve set-up procedure
9. Time of day flashes on and off	a. Power has been out more than two hours, the transformer was unplugged and then plugged back into the wall outlet, the transformer plug was unplugged and then plugged back into the board or the NEXT and REGEN buttons were pressed to reset the valve.	a. Reset the time of day